

Manual

Catenary switchgears B3 FHV, FHF, FHE



Read these instructions before beginning work!

General Information

Handbuch zum Herunterladen



Deutsch



Français



English

Rauscher & Stoecklin AG
Reuslistrasse 32
4450 Sissach
Telephone: +41 61 976 34 00
Fax: +41 61 976 34 22
Email: info@raustoc.ch
Internet: www.raustoc.ch

Table of Contents

1	General Information	4
1.1	Information on this manual	4
1.2	Explanation of symbols	5
1.3	Limitation of liability	6
1.4	Copyright	7
1.5	Warranty provisions	7
1.6	Customer service	7
2	Safety	8
2.1	Intended use	8
2.2	Basic dangers	8
2.3	Responsibility of the operator	9
2.4	Qualifications	10
2.5	Personal protective equipment	12
2.6	Labelling on catenary switchgear	12
2.7	Spare parts	13
3	Transport, packaging and storage	14
4	Technical Data	16
4.1	Technical data on load break switch	17
4.2	Technical Data: Disconnecter	20
4.3	Technical Data: Earthing Switch	23
5	Design and Function	26
5.1	Load break switch function	26
5.2	Disconnecter function	28
5.3	Options and Accessories	29
6	Installation	31
6.1	Installation	31
6.2	Parallel arrangement	33
6.3	Status indication	34
6.4	Earthing switch	34
6.5	High-voltage connection	35
6.6	Preparatory work for initial commissioning	36
7	Servicing	38
7.1	Maintenance schedule	39
7.2	Lubricant	40
7.3	Faults	41
8	Disposal	42
9	Index	43

General Information

1 General Information

1.1 Information on this manual

This manual ensures that the device can be handled safely and efficiently. It is an integral part of the device and must be kept in the immediate vicinity of the device so staff can access it at all times.

Staff must have read and understood this manual before commencing work. Compliance with all the safety instructions and guidelines in this manual is a prerequisite for safe working practices.

Furthermore, local accident prevention regulations and general safety regulations apply to the device's range of application.

This manual is valid for the types specified in the cover sheet.

Illustrations in this manual are provided for basic understanding and may deviate from actual execution.

1.2 Explanation of symbols

Safety instructions

Safety instructions in this manual are indicated by symbols. The safety instructions are introduced by signal words which convey the extent of the danger.



DANGER!

This combination of symbol and signal word indicates an imminently dangerous situation that could lead to death or serious injury if it is not avoided.



WARNING!

This combination of symbol and signal word indicates a potentially dangerous situation that can lead to death or serious injury if it is not avoided.



CAUTION!

This combination of symbol and signal word indicates a potentially dangerous situation that can lead to minor or trivial injury if it is not avoided.



NOTE!

This combination of symbol and signal word indicates a potentially dangerous situation that can lead to material and environmental damage if it's not avoided.

Tips and recommendations



This symbol highlights useful tips, recommendations, and information for smooth, efficient operation.

Special safety instructions

In order to draw attention to specific dangers, the following symbols are used in safety instructions:







DANGER!

This combination of symbol and signal word indicates an imminently dangerous situation due to electric current. Serious or fatal injury may result if this notice is not complied with.

Additional markings

The following markings are used in this manual to highlight instructions, results, lists, references, and other elements:

Marking	Explanation
	Step-by-step instructions
	Results of actions
	References to sections in this manual and to other applicable documents
	Lists without a fixed sequence

1.3 Limitation of liability

All information and instructions provided in this manual have been compiled with regard to the applicable standards and regulations, the state of the art, and our years of knowledge and experience.

The manufacturer is not liable for damages in the following cases:

- failure to comply with this manual
- deviation from the intended use
- deployment of untrained staff
- unauthorized modification
- technical changes
- use of unauthorized spare parts

The actual scope of delivery may deviate from the explanations and information provided herein in the case of a special design or the utilisation of additional order options or as a result of the latest technical changes.

The obligations agreed upon in the supply contract, the General Terms and Conditions, the manufacturer's conditions of delivery, and the legal regulations in place at the time of conclusion of the agreement apply.

1.4 Copyright

The contents of this manual are protected by copyright. Its use is permitted within the scope of the use of the device. Any additional use is prohibited without the written approval of the manufacturer.

1.5 Warranty provisions

The warranty provisions are contained in the manufacturer's General Terms and Conditions of Sale.

1.6 Customer service

Our customer service is available to provide you with technical information:

In addition, we are always interested in information and experience you have gathered by using the product and anything that could be valuable for improving the product.

Switzerland and other countries

Switzerland and countries not listed herein are directly supported by the manufacturer.

Address	Rauscher & Stoecklin AG Reuslistrasse 32 4450 Sissach
Telephone	+41 61 976 34 00
Fax	+41 61 976 34 22
Email	info@raustoc.ch
Internet	www.raustoc.ch

Safety

2 Safety

This section provides an overview of all important safety concerns relating to personnel protection and safe use. Other task-related safety instructions are included in the sections on the individual life phases.

2.1 Intended use

The catenary switchgear is used to switch catenary sections of railway systems on and off in accordance with the technical data  *Section 4 "Technical Data" on page 16.*

The catenary switchgear is suitable for outdoor use.

The catenary switchgear is usually mounted on portals or masts or in tunnels at the appropriate height; the operator's specifications must be complied with.

The catenary switchgear is usually activated by a manual or electrical drive which is coupled via a suitable mechanical connection.

Intended use also includes compliance with all information in this manual.

Any additional or other use that exceeds the intended use is misuse.



WARNING!

Danger due to misuse!

Misuse of the catenary switchgear can lead to dangerous situations.

2.2 Basic dangers

The residual risks presented by the use of the device, including intended use, are described in the following section.

In order to reduce risks of injury and material damage and to avoid dangerous situations, the safety instructions listed here and the safety instructions in the other sections of this manual must be complied with.

Electric current



DANGER!

Danger of deadly injury due to electrical current!

Damaged insulation and components present a danger of deadly injury due to flashover and electric shock.

- If insulation is damaged, switch off the voltage supply and have it repaired.
- Only allow electricians to work on the electrical system.
- Establish a voltage-free state before commencing work on live parts of the electrical systems and equipment. Observe these five safety rules:
 - Disconnect.
 - Secure against reconnection.
 - Verify absence of voltage.
 - Earth and short-circuit.
 - Cover or block off adjacent live parts.

Corrosive atmosphere



NOTE!

Oxidation occurs during use in a highly corrosive atmosphere!

Various parts of the catenary switchgear are made from hot-dip galvanised steel. They may start to rust in a highly corrosive atmosphere.

The electrically conducting parts of the catenary switchgear are made from coated copper. They become discoloured when used in a corrosive atmosphere.

Contact the manufacturer for further information (see page 2 for contact address).

2.3 Responsibility of the operator

Operator

The operator is the person who operates the device for commercial or economic purposes or provides it to a third party for use/application and bears legal product responsibility for protecting the user, staff, or third parties during operation.

Safety

Operator obligations

The device is used in the commercial sector. The operator of the device is therefore subject to the legal obligations relating to occupational safety.

In addition to the safety instructions in this manual, the safety, accident prevention, and environmental protection regulations applying to use of the device must be complied with.

The following is especially relevant:

- The operator must ensure that all persons handling the device have read and understood this manual. Furthermore, he must regularly train staff and inform them of the dangers. It is recommended that corresponding functional tests (circuits) be prescribed.
- The operator must provide staff with the necessary protective equipment and make its wear mandatory.
- The operator must ensure that the maintenance intervals described in this manual are adhered to.
- The operator may set down prescriptions for handling the catenary switchgear that go beyond those set out in this manual. These must, however, be coordinated with the manufacturer (see page 2).

2.4 Qualifications

The various tasks described in this manual place different demands on the qualifications of the persons carrying out those tasks.



WARNING!

Danger if personnel is not sufficiently qualified!

Insufficiently qualified persons are unable to evaluate the risks associated with handling the device, thus leaving themselves and others exposed to risk of serious or fatal injury.

- Only allow qualified persons to perform the work.
- Keep insufficiently qualified persons away from the work area.

Only those persons that can be expected to perform the work in a reliable manner may be authorized to work. Persons whose ability to respond is influenced by drugs, alcohol, or medication, for example, are prohibited from performing work.

The qualifications required of persons for the performance of various tasks are listed in this manual below:

Electrician

Due to his technical training, knowledge, and experience and familiarity with the relevant standards and regulations, the electrician is able to carry out work on electrical systems and independently identify and avoid potential dangers.

The electrician is specifically trained for the work environment in which he is employed and knows the relevant standards and regulations.

Installer

Due to the training or instruction the operator has provided, the installer is able to professionally install electrical equipment and systems and to recognize possible dangers associated with improper behaviour.

The installer must comply with the legal requirements in the accident prevention regulations.

Operator

Due to the training or instruction the operator has provided, the machine operator is able to professionally operate electrical equipment and systems and to recognize possible dangers associated with improper behaviour.

The machine operator must comply with the legal requirements in the accident prevention regulations.

The operator must instruct his personnel on a regular basis. A training report containing the following minimum content must be prepared in the interest of tracking:

- Instruction date
- Name of the person instructed
- Instruction content
- Name of the person providing the instruction
- Signatures of the person instructed and the person instructing

2.5 Personal protective equipment

Personal protective equipment is used to protect personnel from adverse effects on health and safety while at work.

Personnel must wear personal protective equipment during various work activities on and with the device, details of which are separately provided in the individual sections of this manual.

Description of personal protective equipment

Personal protective equipment is explained below:



Protective gloves

Protective gloves are used to protect the hands against friction, excoriations, pricks, deep cuts, and contact with hot surfaces.

2.6 Labelling on catenary switchgear

Power rating plate

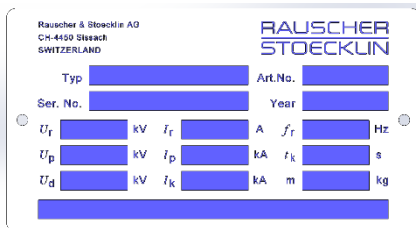

Fig. 1: Power rating plate

A power rating plate (Fig. 1) containing the following information is located on the equipment rack of the catenary switchgear:

- Device type
- Product number
- Serial number
- Year of manufacture
- Rated insulation voltage
- Rated operating current
- Rated frequency
- Rated withstand surge voltage
- Rated surge current
- Duration of short circuit
- Short-duration power frequency withstand voltage
- Rated short-time withstand current
- Weight

These values must not be exceeded.

2.7 Spare parts



WARNING!

Risk of injury due to use of incorrect spare parts!

The use of incorrect or defective spare parts can result in danger to personnel and cause damage, malfunction, or total failure.

- Use only original spare parts from the manufacturer or spare parts approved by the manufacturer.
- Always contact the manufacturer in case of doubt.



Warranty loss

If unauthorized spare parts are used, the manufacturer's warranty will be voided.

Purchase spare parts from official distributors or directly from the manufacturer. See page 7 for contact details.

Please provide the following information in order to guarantee a fast and efficient response from our customer service:

- Series no. and type (see power rating plate)
- detailed description of the parts to be replaced, with photos if possible.

3 Transport, packaging and storage

Transport



NOTE!
Risk of damage

The catenary switchgear must be transported in horizontal and closed position.

A transport belt must be used to secure the movable insulator against automatic opening.

The catenary switchgear, especially the insulators and the vacuum circuit-breaker (only for load break switches), must be protected against hard external blows.

The catenary switchgear must be lifted only on the equipment rack or designated lifting points (Lifting-Eye Nut).

When lifting the catenary switchgear, the lifting devices must be adapted to its weight (as indicated on the power rating plate).

The operator is responsible for ensuring compliance with the safety precautions.

Transport inspection

Check the delivery immediately upon receipt to ensure it is complete and was not damaged during transport.

If there is visible transport damage to the exterior, proceed as follows:

- Refuse the delivery or accept it only with reservations.
- Record the extent of the damage in the transport documents or on the haulier's delivery note.
- Lodge complaint.



Lodge a complaint about each defect as soon as it is identified. Claims for compensation can only be made within the applicable complaint periods.

Packaging

Individual packages are packaged in accordance with the transport conditions to be expected. Only environmentally-friendly materials have been used for packaging.

Packaging should protect individual components against transport damage, corrosion, and other damage until installation. Therefore, do not destroy the packaging and only remove it just before installation.

Handling packaging materials

Dispose of packaging material in accordance with the applicable legal provisions and local regulations.



NOTE!

Risk to the environment due to incorrect disposal!

Packaging materials are valuable raw materials and can be re-used in many cases, processed in a useful way, or recycled. Incorrect disposal of packaging materials can pose risks to the environment.

- Properly dispose of packaging materials.
- Comply with the applicable local disposal regulations. If necessary, commission a specialist company with disposal.

Storage of packages

Store packages under the following conditions:

- Do not store outside.
- Store in a dry, dust-free location.
- Do not expose packages to aggressive media.
- Protect from solar radiation.
- Avoid mechanical impact.
- Storage temperature: 15-35 °C.
- Relative air humidity: max. 60 %.
- For storage periods of more than three months, check the general condition of all parts and packaging on a regular basis. If necessary, renew or replace the preservatives.



The packages may contain instructions on storage that exceeds the requirements set out here. Comply with these instructions.

Technical Data

4 Technical Data

Technical features

The catenary switchgear is comprised of:

- torsion-resistant equipment rack
- effortless actuation axis (connector for actuation)
- silicone post insulators
- reliable main flow path
- electrical connection points
- arc control device (except for earthing switch)

Standards

The catenary switchgear meets the requirements of the current applicable version of the following standards:

- EN 50152-2
- EN 62271-1
- EN 62271-102 and EN 62271-103

Each catenary switchgear is tested in accordance with the internal R&S test procedure. This procedure is also based on the current applicable version of EN 62271-1.

Switch types

Load break switch

A load break switch is a mechanical system that has an insulation distance in an open state in accordance with the relevant standard. It is able to open and close an electric circuit as long as the rated current is not exceeded. It also absorbs a limited number of activations for short circuit. A load break switch is also able to bear currents under standard conditions as well as under non-standard conditions (such as short-circuit power) for a specific period.

Disconnecter

A disconnector is a mechanical system that has an insulation distance in an open state in accordance with the relevant standard. It is able to open and close an electric circuit as long as the current is negligible. A disconnector is also able to bear currents under both standard and non-standard conditions (such as short-circuit power) for a defined period.

Earthing switch

An earthing switch is a mechanical system that reliably earths the insulated track sections. An earthing switch is also able to bear currents under non-standard conditions (such as short-circuit power) for a defined period.

4.1 Technical data on load break switch

Available designs

FHV-B3 – with two fixed connection points

Nominal data

		15kV	25kV	
Rated voltage	U_n	15	25	kV
Rated insulation voltage (according to IEC 62497-1)	U_{Nm}	17.5	27.5	kV
Rated alternating voltage (according to EN 62271-1)	U_r	36	52	kV
Rated frequency	f_r	16.7	50	Hz
Rated operating current	I_r	2,000	2,000	A

Rated short-duration voltages

		15kV	25kV	
1 minute short-duration power frequency withstand voltage (50Hz, dry and wet)	U_a			
A – against the earth and between the poles		70	95	kV
B – across the isolating distance		95	110	kV
Nominal short-duration surge voltage (1.2/50 μ s)	U_{Ni}			
A – against the earth and between the poles		170	250	kV
B – across the isolating distance		195	290	kV

Short-circuit holding current

		15kV	25kV	
Rated short-time withstand current	I_k	40	31.5	kA
Rated surge current	I_p	100	80	kA
Duration of short circuit	t_k	1	3	s

Inrush and breaking currents

		15kV	25kV	
Nominal breaking current at power factor 0.7	I_{break}	2,000	2,000	A
Nominal breaking current at power factor 0.7	I_{make}	2,000	2,000	A
Cable breaking current	I_{cc}	10	10	A
Short-circuit inrush current (duration 0.2s)	I_{ma}	20	20	kA
Increased short-circuit inrush current (pre-arcing horns)	I_{ma}	32	32	kA

Technical Data

Geometry

	15kV	25kV	
Creepage distance of support insulators (silicone)	870	1610	mm
Power stroke of pivot lever	120	180	mm
Weight	see power rating plate		

Operating life

Mechanical life	10,000	Cycles
Short-circuit inrush current	I_{ma} 5	On

Environmental conditions

Operating temperatures	-30 to +40	°C
Relative air humidity	100	%
Solar radiation	1,000	W/m ²
Operating altitude	1,000	m.ü.NN
Icing-up	10	mm
Contamination level (according to IEC 62497-1)	PD4B	
Wind speeds	34	m/s

Options

	FHV-B3
Forced earthing	✓
Status indication	✓
Parallel circuit	✓
Pre-arcing horns (increased making capacity)	✓

Dimensions of load break switch

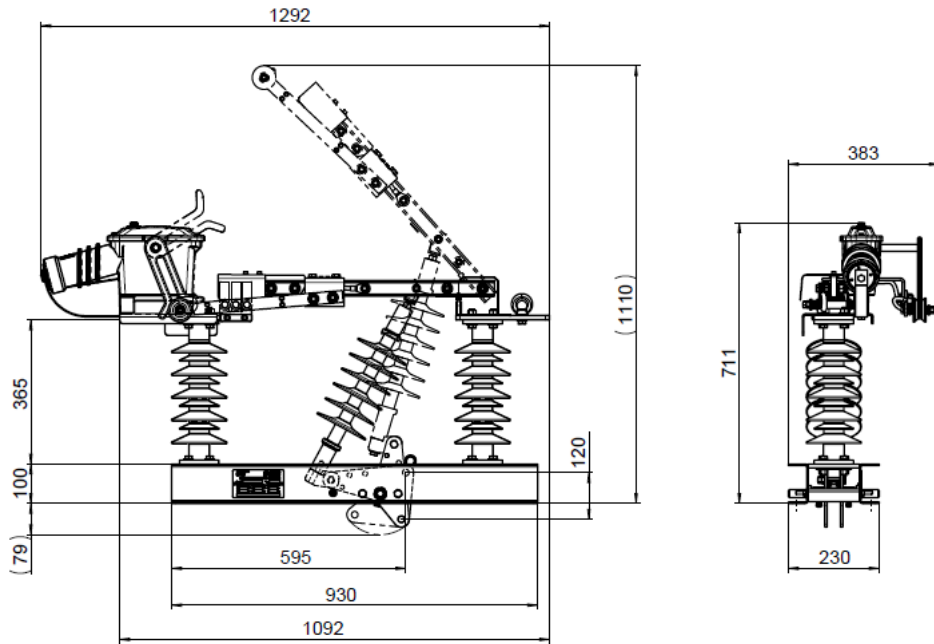

Fig. 2: Dimensions FHV-B3-15/S

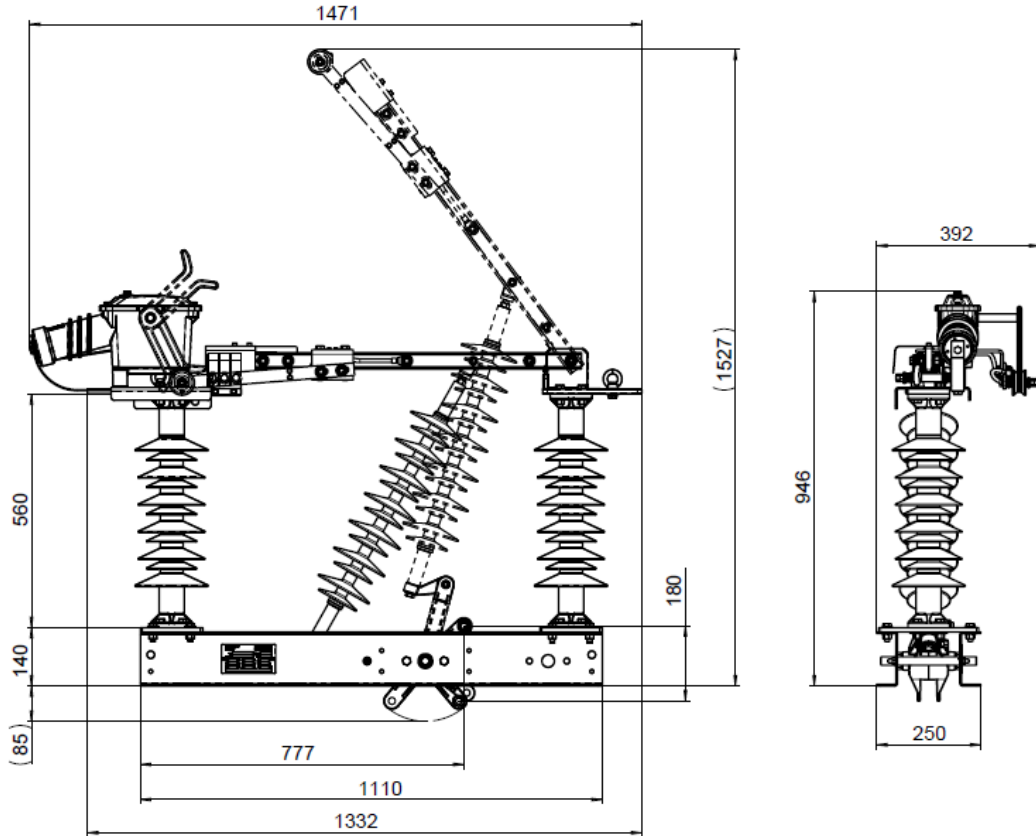

Fig. 3: Dimensions FHV-B3-25/S

Technical Data

4.2 Technical Data: Disconnecter

Available designs

FHF-B3 – with two fixed connection points

Nominal data

		15kV	25kV	
Rated voltage	U_n	15	25	kV
Rated insulation voltage (according to IEC 62497-1)	U_{Nm}	17.5	27.5	kV
Rated alternating voltage (according to EN 62271-1)	U_r	36	52	kV
Rated frequency	f_r	16.7	50	Hz
Rated operating current	I_r	2,000	2,000	A

Rated short-duration voltages

		15kV	25kV	
1 minute short-duration power frequency withstand voltage (50Hz, dry and wet)	U_a			
A – against the earth and between the poles		70	95	kV
B – across the isolating distance		95	110	kV
Nominal short-duration surge voltage (1.2/50 μ s)	U_{Ni}			
A – against the earth and between the poles		170	250	kV
B – across the isolating distance		195	290	kV

Short-circuit holding current

		15kV	25kV	
Rated short-time withstand current	I_k	40	31.5	kA
Rated surge current	I_p	100	80	kA
Duration of short circuit	t_k	1	3	s

Inrush and breaking currents

		15kV	25kV	
Breaking current at power factor 0.1	I_{break}	2	2	A
Inrush current at power factor 0.1	I_{make}	2	2	A
Breaking current at power factor 0.35		6	6	A

Geometry

	15kV	25kV	
Creepage distance of support insulators (silicone)	870	1610	mm
Power stroke of pivot lever	120	180	mm
Weight	see power rating plate		

Operating life

Mechanical life	10,000	Cycles

Environmental conditions

Operating temperatures	-30 to +40	°C
Relative air humidity	100	%
Solar radiation	1,000	W/m ²
Operating altitude	1,000	m.ü.NN
Icing-up	10	mm
Contamination level (according to IEC 62497-1)	PD4B	
Wind speeds	34	m/s

Options

	FHF-B3
Forced earthing	✓
Status indication	✓
Parallel circuit	✓

Technical Data

Disconnecter dimensions

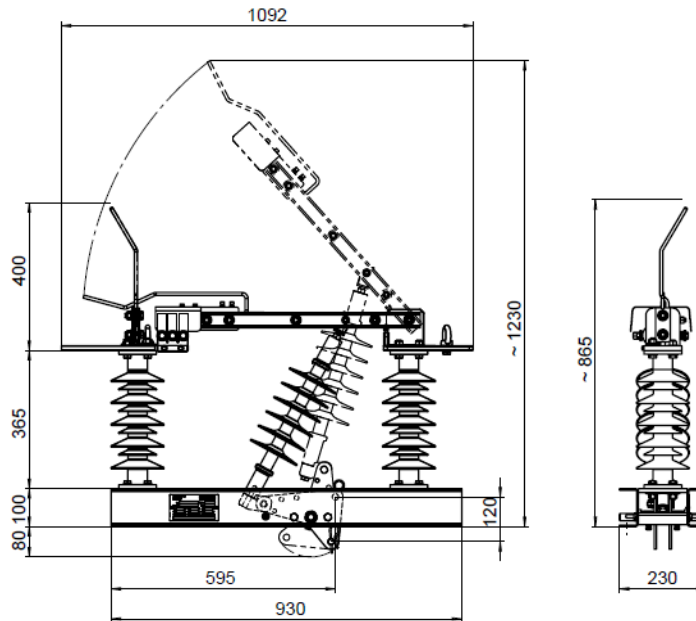

Fig. 4: FHF-B3-15/S dimensions

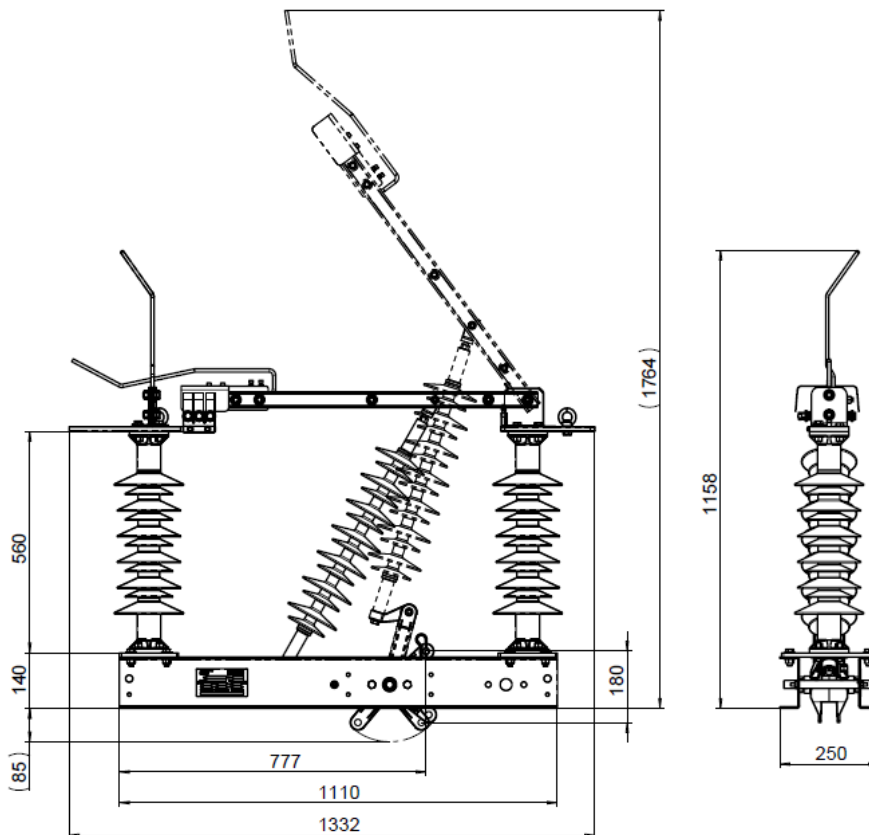

Fig. 5: FHF-B3-25/S dimensions

4.3 Technical Data: Earthing Switch

Available designs

FHE-B2 – with two fixed connection points

Nominal data

		15kV	25kV	
Rated voltage	U_n	15	25	kV
Rated insulation voltage (according to IEC 62497-1)	U_{Nm}	17.5	27.5	kV
Rated alternating voltage (according to EN 62271-1)	U_r	36	52	kV
Rated frequency	f_r	16.7	50	Hz
Rated operating current	I_r	2,000	2,000	A

Rated short-duration voltages

		15kV	25kV	
1 minute short-duration power frequency withstand voltage (50Hz, dry and wet)	U_a			
A – against the earth and between the poles		70	95	kV
B – across the isolating distance		95	110	kV
Nominal short-duration surge voltage (1.2/50 μ s)	U_{Ni}			
A – against the earth and between the poles		170	250	kV
B – across the isolating distance		195	290	kV

Short-circuit holding current

		15kV	25kV	
Rated short-time withstand current	I_k	40	31.5	kA
Rated surge current	I_p	100	80	kA
Duration of short circuit	t_k	1	3	s

Inrush and breaking currents

		15kV	25kV	
Short-circuit inrush current (standard, class E0)		0	0	kA
Increased short-circuit inrush current (pre-arcing horns)	I_{ma}	32	32	kA

Technical Data

Geometry

	15kV	25kV	
Creepage distance of support insulators (silicone)	870	1610	mm
Power stroke of pivot lever	120	180	mm
Weight	see power rating plate		

Operating life

Mechanical life		10,000	Cycles
Short-circuit inrush current	I_{ma}	0	On
Increased short-circuit inrush current (pre-arcing horns)	I_{ma}	2	Ein

Environmental conditions

Operating temperatures	-30 to +40	°C
Relative air humidity	100	%
Solar radiation	1,000	W/m ²
Operating altitude	1,000	m.ü.NN
Icing-up	10	mm
Contamination level (according to IEC 62497-1)	PD4B	
Wind speeds	34	m/s

Options

	FHE-B3
Status indication	✓
Parallel circuit	✓
Pre-arcing horns (increased making capacity)	✓

Earthing switch dimensions

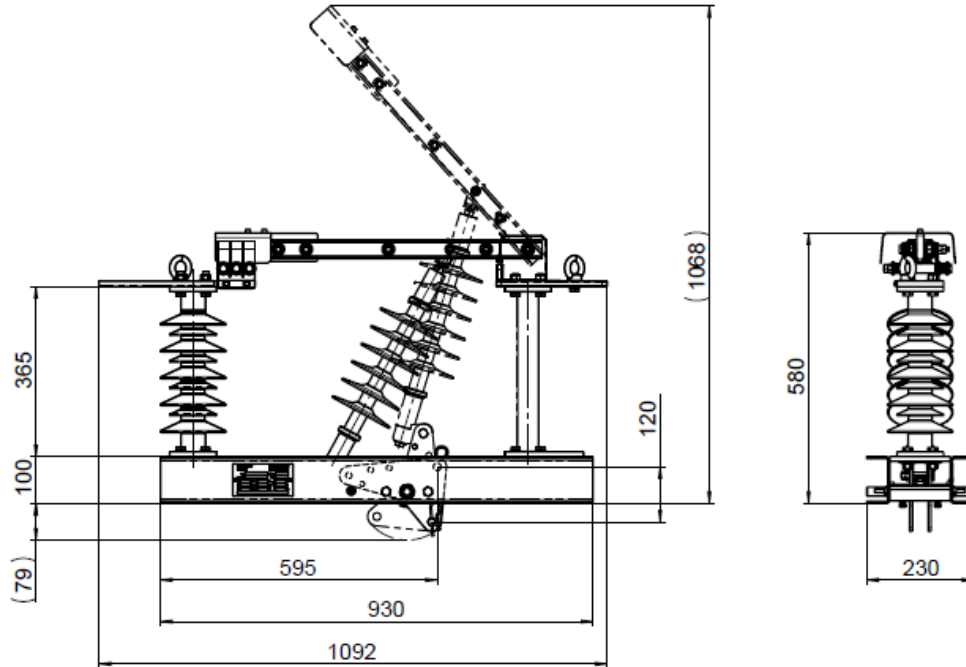

Fig. 6: FHE-B3-15/S dimensions

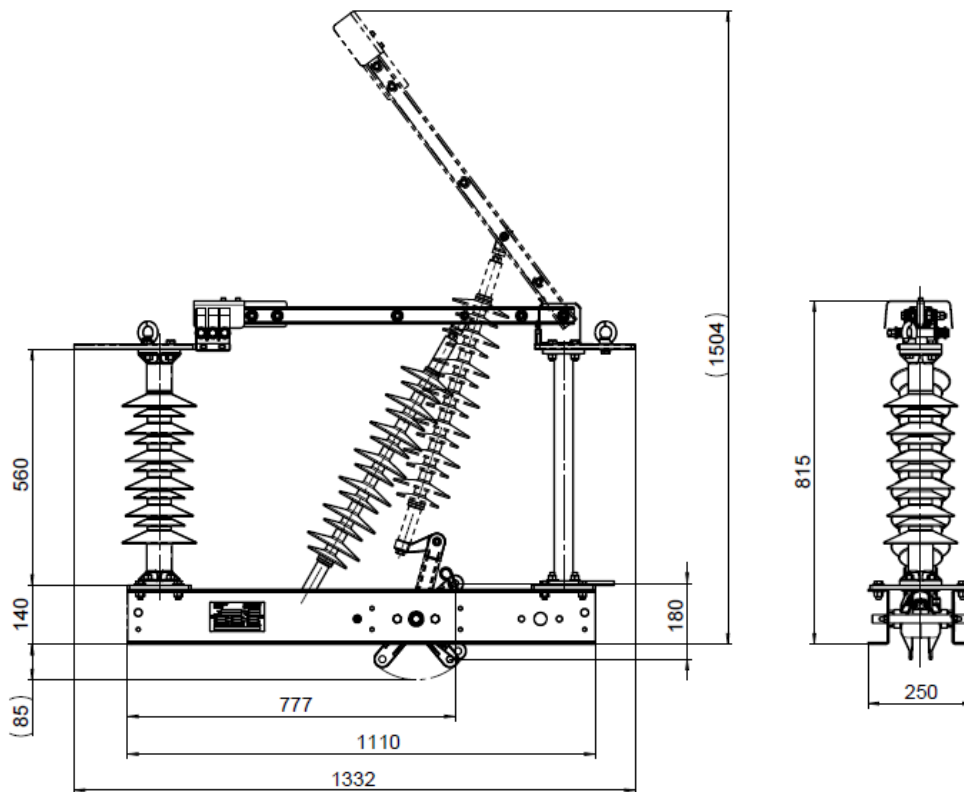

Fig. 7: FHE-B3-25/S dimensions

5 Design and Function

Basic design

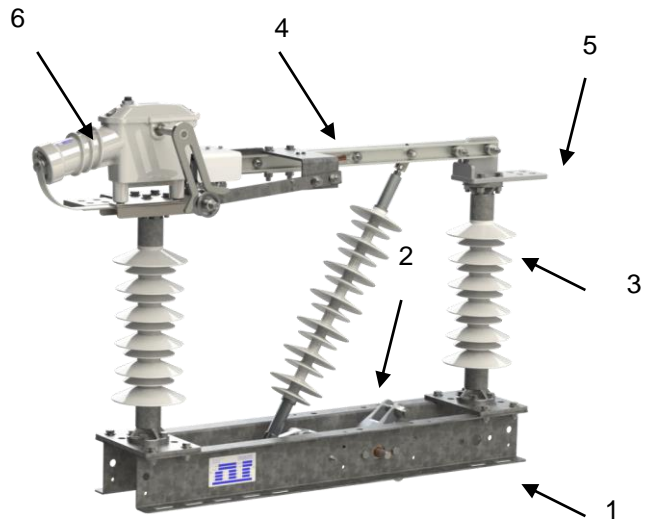
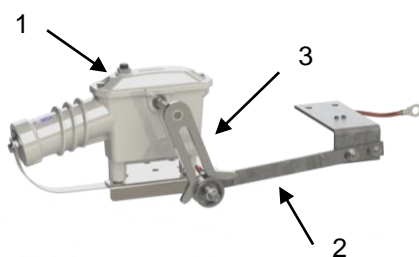

Fig. 8: Basic design (example: FHV-B3)

1. torsion-resistant equipment rack:
for transporting and installing the catenary wire switchgear
2. effortless actuation axis:
for connecting the mechanical actuation
3. silicone post insulators:
for insulating between high voltage and earth potential
4. reliable main flow path:
for transmitting the rated normal current
5. electrical connection points:
for connecting electrical lines
6. Arc control device:
for controlling the switch arc created

5.1 Load break switch function

Vacuum circuit-breaker



One of the characteristics of the load break switch is that it is able to switch the rated operating current without creating an external arc. The arc is suppressed in a vacuum in the vacuum interrupter (Fig. 13).

1. Vacuum circuit-breaker
2. Actuating lever
3. Switch bracket

The procedure for correct disconnection is explained below.

Fig. 9: Vacuum circuit-breaker

Breaking operation

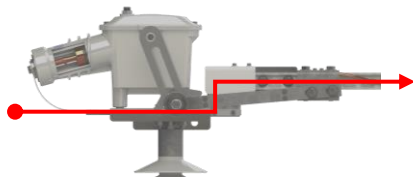

The switch is closed. The current flows through the main flow path from the fixed contact to the stationary contact.

Fig. 10: Closed

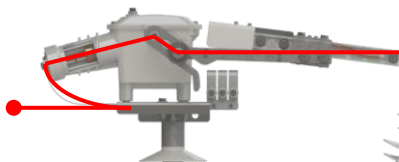

The main flow path is interrupted; the current flows through the vacuum interrupter.

Fig. 11: Sub-path



Once the insulating distance between the contacts is sufficiently large, the mechanics in the vacuum interrupter are activated. The arc is suppressed in the vacuum. The switch is now open.

Fig. 12: Disconnection



The switch has reached its end position. The line is now insulated.

Fig. 13: Disconnecting



NOTE!

Reduction of electrical life

In general, the load break switch is connected in such a way that the supply comes from the fixed contact (vacuum interrupter and spark horns).

If power is supplied from the movable contact part, this can negatively affect the electrical life.

Making operation

The sequence is reversed during switching on.

5.2 Disconnecter function

Arcing horns

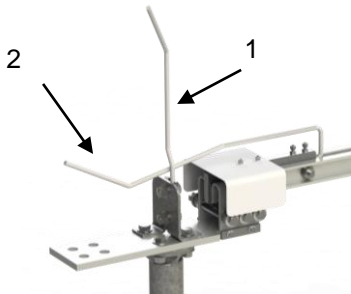

Fig. 14: Arcing horns

The switch arc is suppressed in the air at the arcing horns (Fig.18).

1. Arcing horn
2. Breaking horn

The procedure for correct disconnection is explained below.

Breaking operation

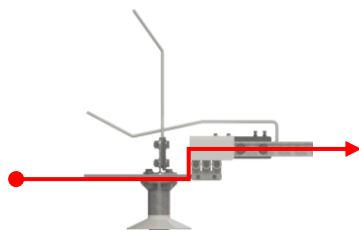

Fig. 15: Closed

The disconnecter is closed. The current flows through the main flow path from the fixed contact to the stationary contact.

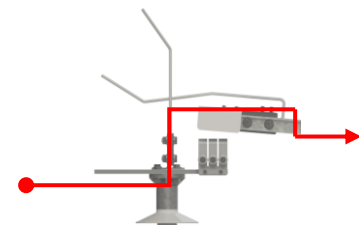

Fig. 16: Switching off

Switching off of small inductive or capacitive currents causes an arc between the arc horn and the breaking horn as soon as the main flow path is interrupted.

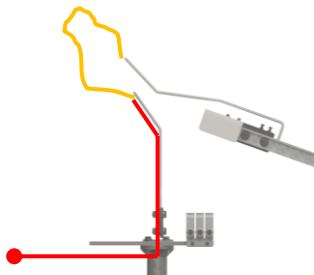

Fig. 17: Separation

The arc breaks as soon as the insulating distance between the contacts is sufficiently large. The disconnecter is now open, and as soon as it reaches the end position, the line is insulated.

Making operation

The sequence is reversed during switching on.

5.3 Options and Accessories

Status indication

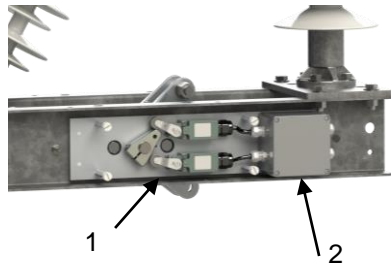

Fig. 18: Status indication

A status indication is installed in the equipment rack in order to bring the safety of the substation to the highest level and to transmit the actual status of the catenary switchgear.

The status indication is optional and is already installed in the mechanism and correctly set. It is weather-resistant and contains the following parts:

1. Limit switches
2. Terminal boxes

The limit switches are set such that each one is activated just before reaching the corresponding end position. They are fully wired to the terminal boxes.

Forced earthing

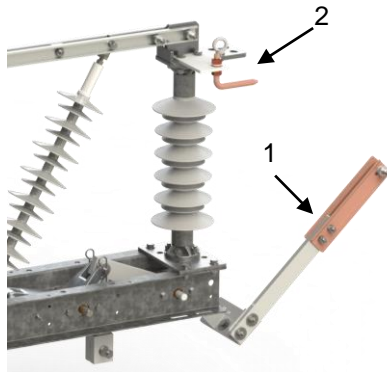

Fig. 19: Forced earthing

Forced earthing is installed in the catenary switchgear in order to automatically and forcibly earth the insulated line section. This option can only be installed in a B2 design.

Forced earthing is optional and is already installed in the mechanism and correctly set. It contains the following parts:

1. Earth rail
2. Earth finger

The earth finger is installed on the connecting point and fits correctly into the movable earth rail. This occurs just before it reaches the end position.

Pre-arcing horns

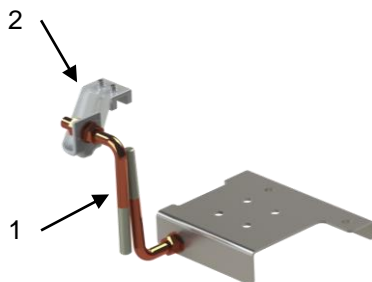

Fig. 20: Pre-arcing horns

In order to protect the vacuum circuit-breakers at the load break switch from excessive currents during switch-on (>20kA), pre-arcing horns are installed parallel to the main contact.

This option is also used to protect the main contact at the earthing switch.

The pre-arcing horns are optional and are already installed in the mechanism and correctly set. They contain the following parts:

1. Pre-arcing horns
2. Fixing bracket (movable)

When high currents are switched on, an arc forms between the two pre-arcing horns before the vacuum circuit-breaker has been switched on. The arc remains until the main contact is closed.

Design and Function

Parallel arrangement

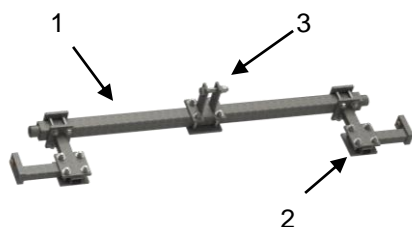

Two single-pole switches can be combined to form a two-pole switch. A coupling kit is required for this purpose. This kit connects the axes of the two switches in such a way that they can be actuated at the same time.

The pre-installed coupling kit is supplied separately and consists of the following parts:

1. Connection shaft
2. Elbow
3. Switch lever (including bolts and cotter pins)

Fig. 21: Coupling kit

6 Installation

Electric current



DANGER!

Danger of deadly injury due to electrical current!

There is danger of deadly injury during work on live parts.

- Allow only electricians to work on electrical components.
- Establish a voltage-free state before commencing work on live parts of the electrical systems and equipment. Observe these five safety rules:
 - Disconnect.
 - Secure against reconnection.
 - Verify absence of voltage.
 - Earth and short-circuit.
 - Cover or block off adjacent live parts.

6.1 Installation

General information

The catenary switchgear is delivered fully installed and properly set and tested.

Preparation

Personnel: ■ Installer

Prior to installation, the catenary switchgear must be checked to ensure it is complete and correct.

The required accessories must also be checked to ensure they are complete.

Remove the transport lock of the movable contact.

Check all components for damage.

Manual operation



DANGER!

Risk of injury during manual operation

The operation of the catenary switchgear requires space and strength.

- Always make sure that the catenary switchgear is sufficiently fastened before it is manually operated.
- Make sure your hands are outside the hazard zones (main contact, activation axis) so as to avoid bruises.

Installation

Installation in the catenary mast

Personnel: ■ Installer

The operator's instructions must be complied with.



NOTE!

Risk of damage

Observe the transportation instructions when transporting and lifting the catenary switchgear (↪ *Section 0 "Transport, packaging and storage" on page 14*).

The catenary switchgear can be fastened to a metallic structure or to concrete. In order to guarantee effortless switching on and off, it must be ensured that the surface is even and adequately dimensioned for the weight (see power rating plate).



NOTE!

Flashovers to adjacent parts

The distance between the high-voltage parts of the catenary switchgear and other earthed components must be sufficient to prevent flashovers.

The catenary switchgear is fastened to the load-bearing structure with 4 M16 screws.

The equipment rack must be subject to defined earthing. The labelled earth point must be used for this purpose.

Interfaces:

1. Fastening holes
2. Earth point

The correct tightening torques for these and other screw connections are shown in this table:

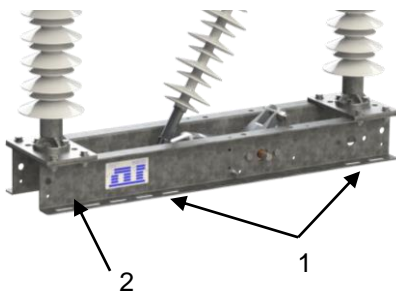

Fig. 22: Fastening & earthing

Thread	Max. tightening torque [Nm]
M4	2.6
M6	8.8
M8	21.4
M10	44.0
M12	74.0
M16	183.0

6.2 Parallel arrangement

Installation of the coupling kit

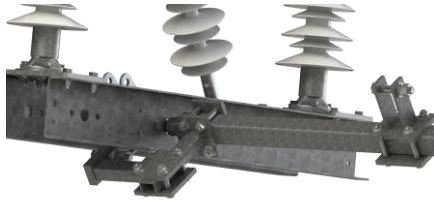

Fig. 23: Installation of the coupling kit

Personnel: ■ Installer

Before the coupling kit is installed, one of the two catenary switchgears must be fastened to the load-bearing structure.

Push the connection shaft onto the axes of both switchgears. The second switchgear is now in position as well.

Fasten the second switchgear to the load-bearing structure.

If necessary, push the elbows onto the connection shaft until they are in the correct position and the pivot lever can be clamped.

Ideally, the switch lever should be placed in the middle of the connection shaft. However, deviations of up to 200 mm (left or right) are permissible.



NOTE!

Unsymmetrical switching

The two connected switches do not run symmetrically, because of the tolerances of the switches. The little difference between the two switching points have no negative effects on the system.

Installation

6.3 Status indication

Connecting the cable

Personnel: ■ Electrician

The status indication is already installed in the equipment rack ex works and can be electrically connected on the ground or on the load-bearing structure.

With this in mind, remove and store the terminal box.

Feed the cable into the cable gland.

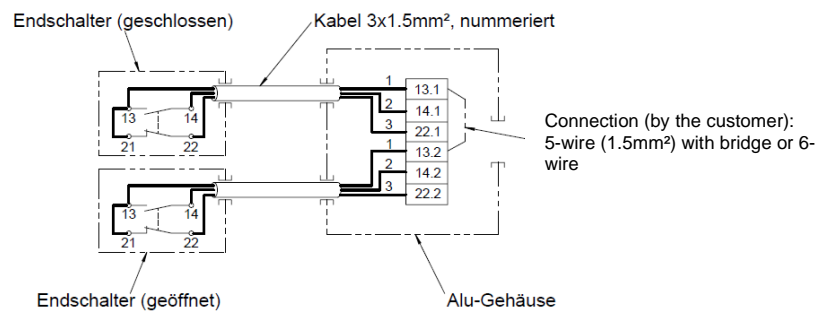

Fig. 24: Wiring diagram

Connect the 5-wire or 6-wire cable to the terminal block as shown in the diagram and close the terminal box again. If using a 5-wire cable, a bridge must be mounted as shown in the diagram.

The cable is then laid downwards along the load-bearing structure and into either the motordrive or a cable conduit on site.

The operator's instructions must be complied with.

6.4 Earthing switch

Earthing earth pole

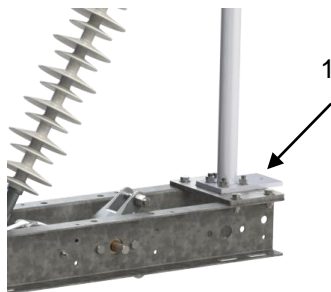

Fig. 25: Earth connection

Personnel: ■ Installer

The earthing switch must be earthed at the designated earth point (1) on the base plate of the earth pole.

The earth connection used must have a sufficient cross-section to prevent excessive heating by the inrush short-circuit current.

6.5 High-voltage connection

Connecting the lines

Personnel: ■ Electrician

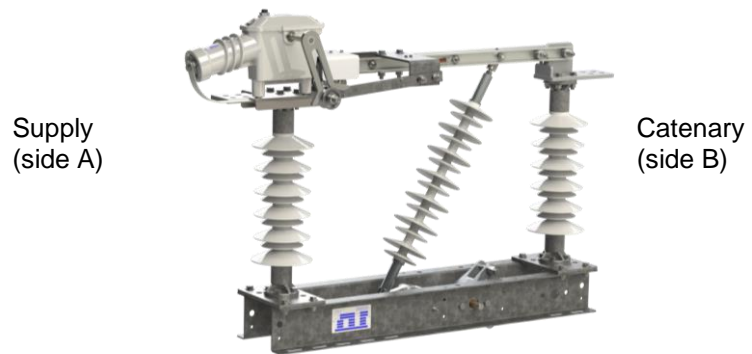

Fig. 26: Installation direction (example FHV-B3)



NOTE!



Reduction of electrical life

In general, the load break switch is connected in such a way that the supply comes from the fixed contact (vacuum interrupter and spark horns).

If power is supplied from the movable contact part, this can negatively affect the electrical life.



NOTE!



Overheating due to rated normal current

The catenary switchgear may be connected to the high-voltage network only via the electrical connection points. The connections must be adequately dimensioned to prevent overheating.



NOTE!



Reduction in the insulation distance

In order to prevent a reduction in the insulation distance between high voltage and earthing potential, it must be ensured that the external connections do not sag, especially when the cable is being inserted.

Installation

6.6 Preparatory work for initial commissioning

Commissioning



NOTE!

Danger of damage to the switching system

The switching system and all related components may be damaged or destroyed if the catenary switchgear is set incorrectly.

Switching on and off

Personnel: ■ Installer



NOTE!

Danger of damage to the switching system

At first, the catenary switchgear can only be operated manually. If the switchgear is activated by a motordrive, the motordrive should be manually operated (emergency crank handle).

The switching may be electrically activated until the setting is complete.

A stopping tube is built into the rack, which is set in the mechanism in such a way that the contact blade fully penetrates the contact finger without touching the protective tubes, is located in the equipment rack. There is only one safety stop at the open end position which cannot be set but permits the given stroke.

Inspection of main contact

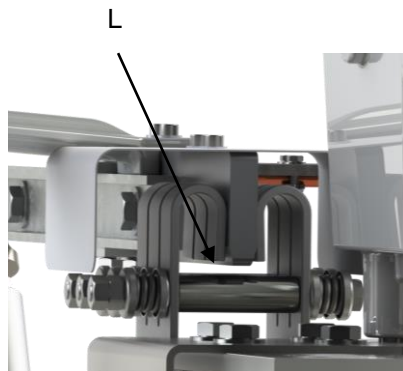

Switches closed: the main contact must be completely closed. This is the case if the distance "L" between the movable contact blade and the protective tubes does not exceed the specified limits. If the measured value is outside tolerance, it must be corrected by adjusting the rod system.

$$L_{\min} = 4\text{mm}$$

$$L_{\max} = 7\text{mm}$$

Fig. 27: Main contact

Inspection of the vacuum circuit-breaker



Fig. 28: Vacuum circuit-breaker

When switching on and off, it must be ensured that the switch operating lever properly actuates the switch bracket and switches the vacuum circuit-breakers. This is the case if a clear mechanical sound is audible.

The contact rolls do not have any or only slight contact with the switch brackets when closed, but must have clear contact before the main contact is separated during opening.

Inspection of the arcing horns

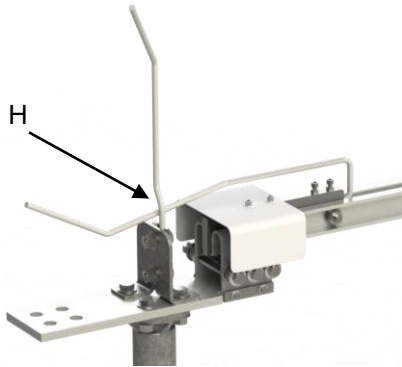

Fig. 29: Arcing horns

Switches closed: the arcing horns must not touch each other. The distance "H" must be checked. Deviations from the specified limits must be corrected by slightly bending the arcing horns.

$$H_{\min} = 4\text{mm}$$

$$H_{\max} = 6\text{mm}$$

The arcing horns must not touch each other before the main contact is separated during opening.

Inspection of pre arcing horns

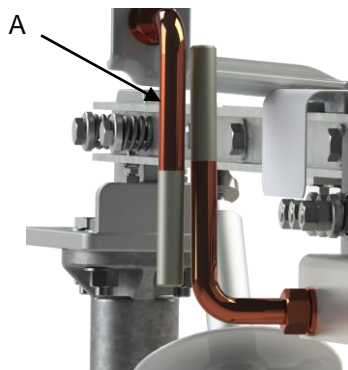

Fig. 30: Pre arcing horns

Switches closed: the distance "A" between both pre arcing horns should be within the given tolerance. The value must be measured if both ends of the pre-arcing horns are at the same level.

$$A_{\min} = 4\text{mm}$$

$$A_{\max} = 5\text{mm}$$

Remote control

Personnel: ■ Operator

After the adjustments are made, an electrically operated switching system may be activated by remote control for the first time.

The switching operations must be monitored on site.

The movements must be complete, effortless, and even. It is normal for the movement to be slowed somewhat when activating the vacuum interrupter.

7 Servicing

Electric current



DANGER!

Danger of deadly injury due to electrical current!

There is danger of deadly injury during work on live parts.

- Allow only electricians to work on electrical components.
- Establish a voltage-free state before commencing work on live parts of the electrical systems and equipment. Observe these five safety rules:
 - Disconnect.
 - Secure against reconnection.
 - Verify absence of voltage.
 - Earth and short-circuit.
 - Cover or block off adjacent live parts.

Improper maintenance



WARNING!

Risk of injury due to improperly executed maintenance work!

Improper maintenance can cause serious injury and considerable material damage.

- Have only qualified personnel perform maintenance work.
- Where components have been removed, ensure proper installation, re-install all fixing devices, and adhere to screw-tightening torques.

The operator's instructions on maintenance of equipment must be complied with.

7.1 Maintenance schedule

Catenary switchgears are practically maintenance-free. The following regular checks are recommended:

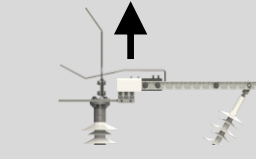
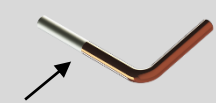
Control point	Desired condition	Maintenance work	Conformity measure	5 years 3000 cycles	10 years 3000 cycles	5x switching on	Significant short circuit
Main contact, contact rolls	surfaces smooth and free of smelted copper	check	replace defective contact parts (only by R&S)	X	X	X	X
Post insulators	free from damage and coarse soiling	check	clean if necessary, replace defective insulators (only by R&S)		X	X	
Contact force	 $F_k > 250N$	inspect using spring balance	re-stress compression springs		X		
Circuit-breakers	continuous when closed, interrupted when open	inspect using ohmmeter (switch bracket connecting strap)	replace defective circuit-breaker (only by R&S)		X	X	
Screws	tightened as per the manual	inspect using torque key	retorque if necessary		X		X
Function	effortless connection as well as "ZU" position as per the manual	perform 3 cycles, check "ZU" position	if necessary, adjust switches as per the manual		X		
Pre-arcing horns	 $L > 120mm$	remeasure	replace heavily arced pre-arcing horns			X	

Servicing

7.2 Lubricant

Barrierta L55/2 is used as a lubricant on Rauscher & Stoecklin railway switches:

Barrierta L55/2 is a reliable and long-term stable and special lubricant with the highest quality and outstanding properties. It is the oldest European quality brand for high-temperature lubricants based on perfluoropolyether oil (PFPE) and is often regarded as a synonym for long-term resistance and temperature stability.

Barrierta L55/2 is chemically inert and for this reason must not be mixed with any other type of grease. It guarantees a long-lasting and reliable function.

In use, Barrierta L55/2 achieves a maintenance schedule of 5 years / 3000 cycles.

Klüberfood NK1 Z 8-001 spray is recommended for cleaning the contacts.

Barrierta L55/2 is NSF H1 registered and therefore compliant with FDA 21 CFR § 178.3570. The use of Barrierta L55/2 contributes to increasing the reliability of the production processes.

7.3 Faults

Improperly executed fault clearance work



WARNING!

Risk of injury due to improper fault clearance!

Improperly executed fault clearance work can cause serious injury and considerable material damage.

- Before starting work, make sure there is sufficient space for performing installation work.
- Pay attention to tidiness and cleanliness at the installation site! Loosely stacked or scattered components and tools can cause accidents.
- Where components have been removed, ensure proper installation, re-install all fixing devices, and adhere to screw-tightening torques.
- allow only electricians to clear faults.

Behaviour in case of faults

Contact the manufacturer if all the work required to clear the fault exceeds the work described in ↪ *Section 6 "Installation" on page 31* and in ↪ *Section 7 "" on page 37* (see page 2 for contact address).

1. In case of faults that present an immediate danger to personnel or material assets, interrupt the power supply immediately.
2. Identify the cause of the fault.
3. Check connections and cables for damage and seating.

Fault cannot be cleared

Contact the manufacturer (see page 2 for contact address).

Disposal

8 Disposal

After the switchgear's period of use has expired, it must be dismantled and disposed of in an environmentally-friendly manner.

Disposal



NOTE!

Risk to the environment due to incorrect disposal!

Incorrect disposal can pose risks for the environment.

- Catenary switchgears can be returned to the manufacturer when their period of use has expired.
- Catenary switchgears do not contain hazardous or poisonous materials.
- Have approved, specialised companies dispose of electronic scrap, electronic components, lubricants, and other auxiliary materials.
- If in doubt, obtain information on environmentally-friendly disposal from the local municipal authorities or specialized disposal companies.

9 Index

Copyright	7	Maintenance	38
Corrosion	9	Maintenance schedule	39
Customer service.....	7	Misuse.....	8
Dangers	8	Operator	10
De-installation.....	41	Packaging	14
Design and function		Personnel.....	10
basic.....	26	prior to commissioning.....	36
disconnecter.....	28	Protective equipment	12
load break switch	26	Qualification	10
Design and Function		Residual risks	8
options and accessories	29	Safety	
Dimensions		general	8
load break switch	19	salty air.....	9
Disconnecter		Service	7
dimensions	22	Spare parts	13
Disposal	41	Standards	16
Earthing switch		Storage	15
dimensions	25	Symbols	
Electric current.....	9	in the manual.....	5
Electrical properties	16	Technical data	
Faults	40	disconnecter	20
Installation.....	31	earthing switch	23
earthing switch	34	load break switch	17
high-voltage connection	35	technical features.....	16
parallel arrangement.....	33	Transport	14
status indication	34	Transport inspection	14
Intended use	8	Use.....	8
Labelling		Warranty provisions	7
power rating plate	12		